

Multi-channel encoder GEL 2701, 2710, 2711

Flange mounting or mounting with torque support

SENSORLINE

LENORD+BAUER

Technical information

version 05.07



GEL 2710

Encoder with round flange



GEL 2711

Encoder with rectangular flange



GEL 2701

Encoder with torque arm



General information

The Multi-channel encoder has been specially designed for the needs of rail vehicle applications.

The encoder (pulse generator) has been designed to provide independent output signals for different control electronics such as motor speed control, wheel slide protection, automatic train protection, distance evaluation or to provide redundant signals for safety requirements

Main features

- Magnetic measuring principle: robust and durable, resistant to dirt, oil and condensation.
- 1 to 8 channels
- Up to three different pulse numbers from one encoder
- Up to 400 pulses per revolution
- Signal channels can be optionally electrically separated for different control electronics
- Voltage and current signal channels
- Phase separation between channels freely selectable (e.g. 90° for additional direction of rotation evaluation)
- Highly accurate signal duty cycle and phase relationship
- Selection of flanges available
- Version with torque arm for mounting directly on the wheel
- Protection class IP 67

The flexible modular design of the encoders make them ideal for not only new project requiring state of the art technology but also for retrofitting existing vehicles.

Functional description

Functional description

Inside the encoder is a metal structure attached to the encoder shaft. The structure is scanned by one or more magnetic sensors. The electronic circuit generates electrical pulses giving output signals in the form of square waves with pre-defined voltage or current level. The output frequency is proportional to the rotational speed of the shaft. The signals are evaluated in the vehicle control electronics.

The use of a magnetic sensor system contributes significantly to the suitability of this encoder for the rigors of rail vehicle applications. The sensors are resistant to adverse conditions such as ingress of dirt, oil or moisture or by condensation due to temperature changes.

The heavy duty design of the encoder includes bearings that have been specially selected to ensure a maintenance free long life in the harshest of environments. The metal structure used are particularly rigid to withstand even extreme shocks and vibrations.

Types of encoder / means of installation

Types GEL 2710, 2711 and 2712 are intended for outside-journal bogies. They are flanged onto the bearing cover of the wheelset and driven (e.g.) by a clutch disc.

The GEL 2701 is suitable for inside-journal bogies. A rotor flange is mounted on the wheelset, enabling the encoder to turn freely. A torque support connected to the bogie frame prevents the encoder from rotating with the wheel.

For all our encoders we offer customer-specific series production with various cables, protective sleeves and plugs.

Multiple channels

From one to eight signal channel outputs are available. These can be arranged as single channels or in groups of channels with a fixed phase relationship. A typical arrangement is a group of two sensors 90° electrically separated for additional direction of travel detection. Other phase separations are possible such as three sensors 120° electrically separated. Combinations of groups are possible such as one single channel plus a group of two sensors 90° separated.

The channels can all be on a common supply voltage or, if required the groups of channels can be electrically isolated with different supply voltages between 10 and 30 V DC

The encoder is designed to provide up to three different pulse numbers. The pulse numbers can be freely assigned to the output channels or channel groups.

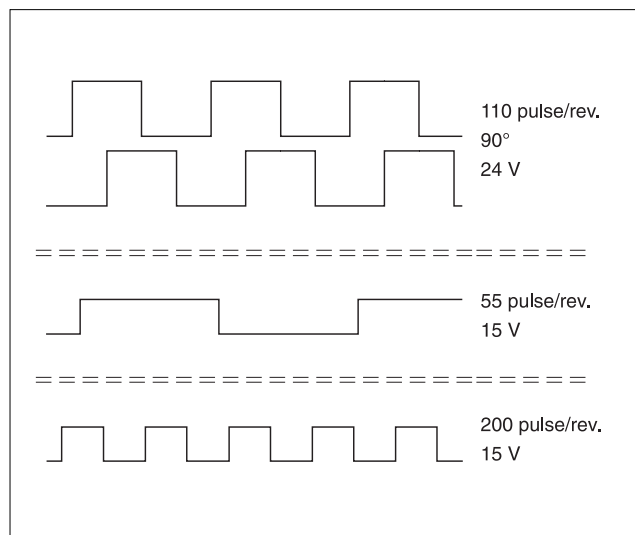

An example of a combination of channels and pulse numbers:

- Motor speed feedback: 2 channels with 90° (elec.) separation 110 pulses per revolution, 24 V DC supply voltage
- Wheel slide protection: 1 channel, 55 pulses per revolution 15 V DC supply voltage
- Automatic train protection: 1 channel, 200 pulses per revolution 15 V DC supply voltage

Technical data

Number of channels	1 ... 8
Phase between 2 or more channels	Standard 90° electrical. Others (e.g. 120°) possible.
Pulse numbers per revolution	1 ... 400*
Duty cycle	50% ± 10 %
Output frequency	0 ... 20 kHz

Voltage output signals

Supply voltage V_s	10 ... 30 V DC
Current consumption per channel (no load)	$I_B \leq 30$ mA
Output signal Voltage level high Voltage level low	square wave, push-pull circuit** typ. $V_s - 2$ V typ. < 2 V

Current output signals

Supply voltage V_s	12 ... 16 V DC
Voltage drop per channel	4 V
Output signal Voltage level high Voltage level low	square wave 14 mA (nominal) 7 mA (nominal)
Connectable load	$(V_s - 4 \text{ V}) / 16 \text{ mA}$

Mechanical data

Max. operating r. p. m.	5000 min ⁻¹
Material Housing Shaft	anodized aluminum stainless steel
GEL 2701	1400 g without cable, without drive
GEL 2710	2000 g without cable, without drive
GEL 2711	
Cable, connector and protection horse are adapted after type of device, specification on request.	

Environmental conditions

Ambient temperature range	-40°C ... +100°C
Shock protection	EN 61373 cat.3
Vibration protection	EN 61373 cat.3
Climatic protection	0 ... 98 % relative humidity, condensing
Electromagnetic compatibility (EMC)	rail vehicles: EN 50121-3-2
Insulation strength EN 60439-1	1.5 kV, 50 Hz, 1 min.
Type test	
conform or exceeds	EN 50155
equivalent	IEC 60571
Protection class	IP 67

* from 202... 400 impulses per revolution no phase relationship between the channels is possible. 1 ... 200 all impulse numbers possible. From 202 ... 400 all straight impulse numbers possible.

** For further details please refer to operating instructions.

Outputs

Voltage output

High level \geq typ. $U_B - 2.0$ V
 Low level < 1.6 V

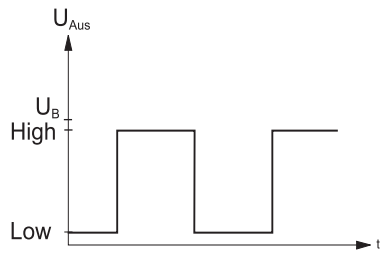

Signal quality

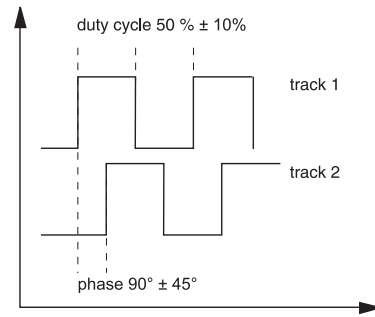

two channel example

Current output

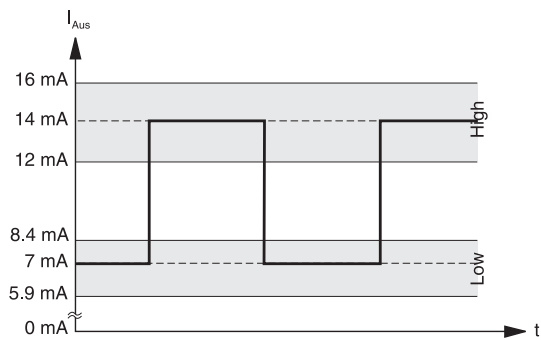

Voltage output with stand still voltage

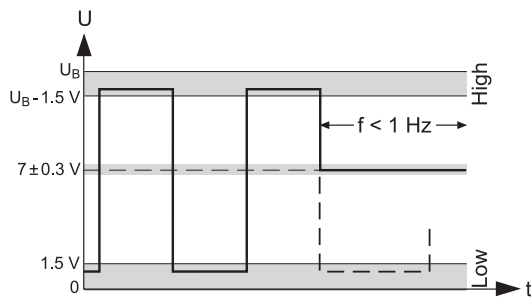

$U_B - 1.5$ V to 85°C , 10 mA, 14 V DC

Encoder GEL 2710

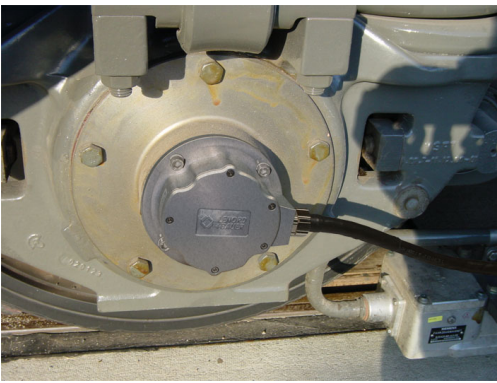

Mounting example GEL 2710

Dimensional drawing GEL 2710 (with rectangular shaft)

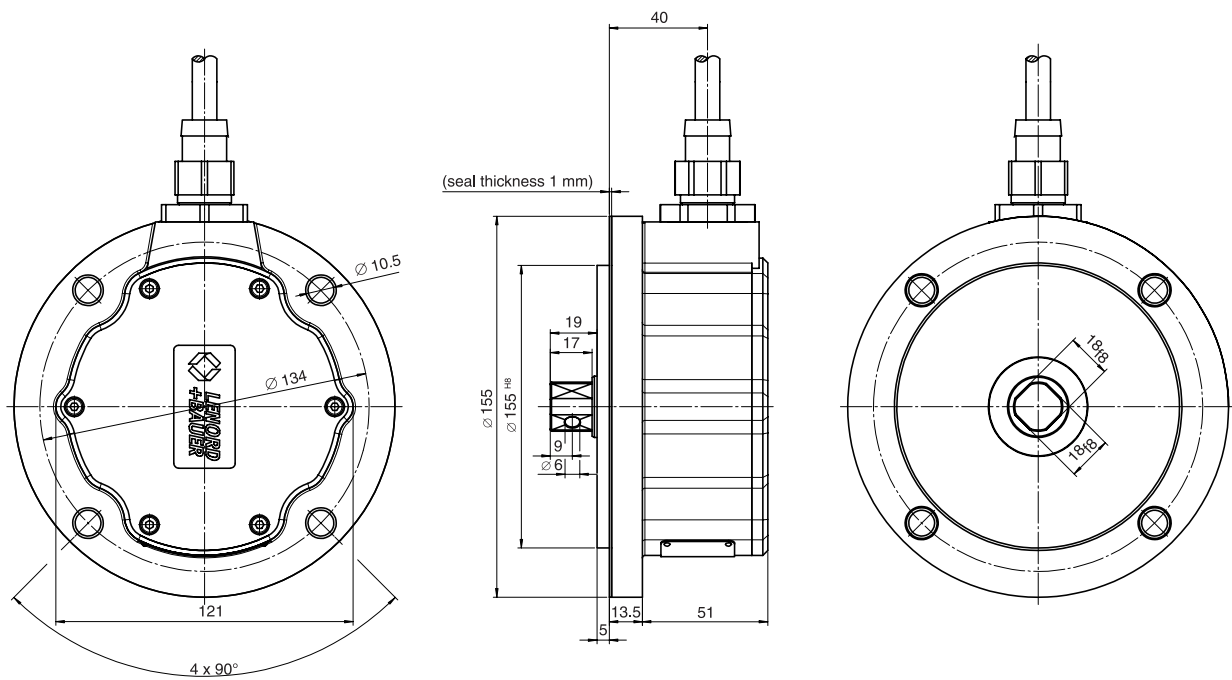

Drive example 1

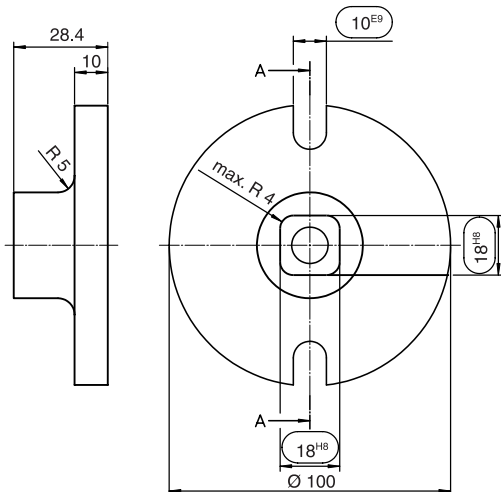

Drive example 2

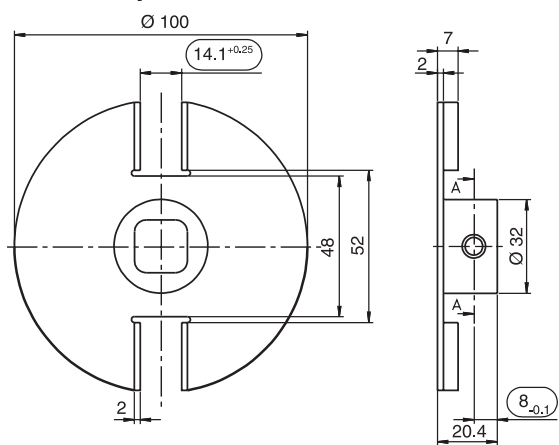

Encoder GEL 2711

Dimensional drawing GEL 2711

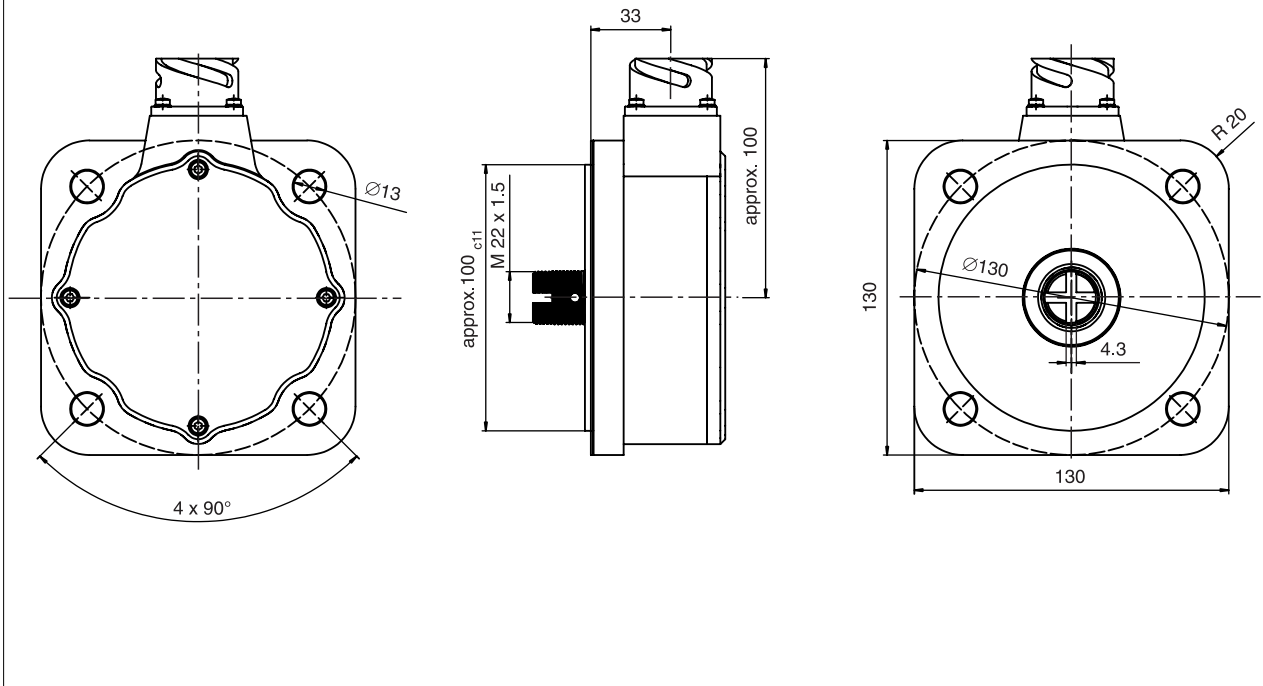

Drive example 1

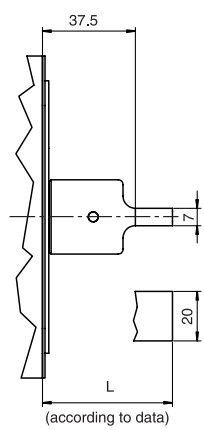

Drive example 2

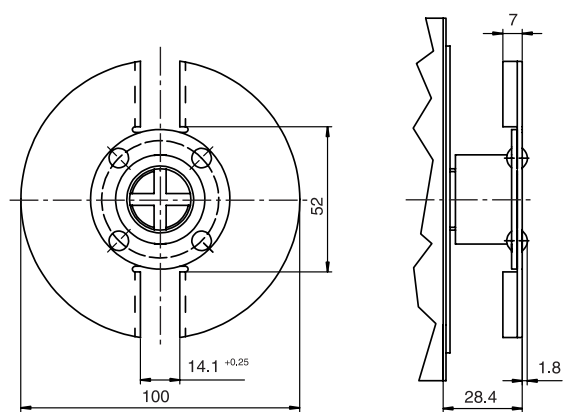

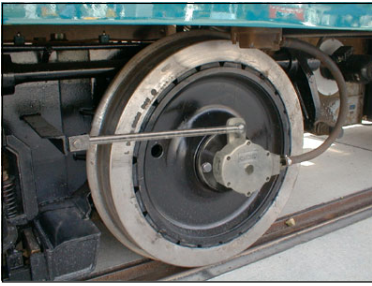

Encoder GEL 2701

The encoder is easily mounted onto a rotor flange which is itself fitted to the wheel centre. The encoder is prevented from rotation with a torque support connected to the vehicle chassis. Rotor flanges can be supplied with different dimensions to suit the application.

Mounting example GEL 2701

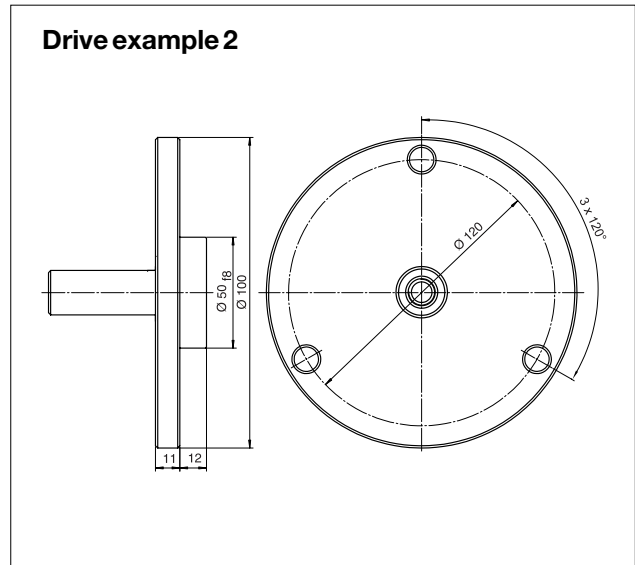
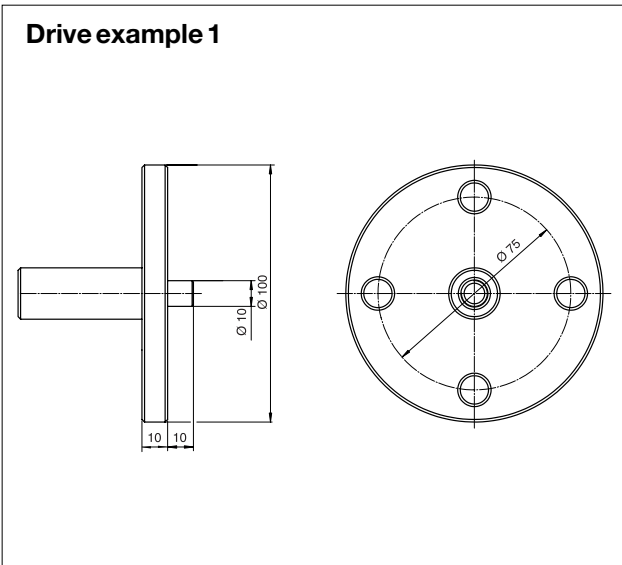
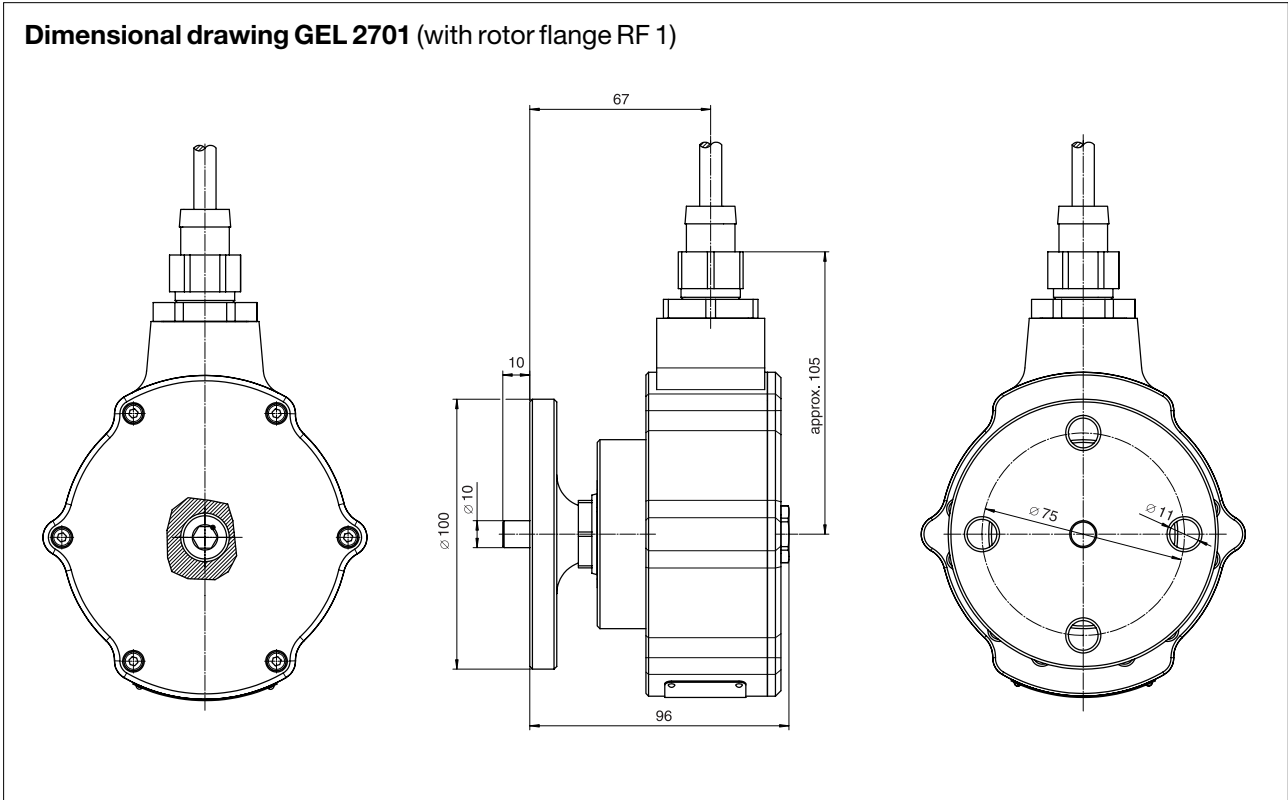

Examples for anti-rotation systems

Torque support via hose

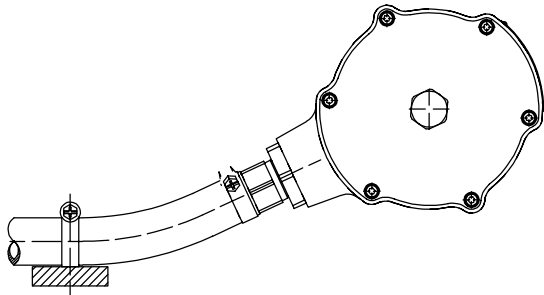

Torque support via arm with ball-shaped head

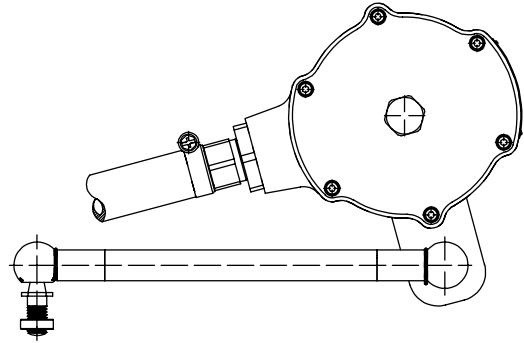

Mounting position of the arm is variable.



... automates motion.

Lenord, Bauer & Co. GmbH
Dohlenstrasse 32
46145 Oberhausen, Germany
Phone: +49 208 9963-0
Fax: +49 208 676292
info@lenord.de
www.lenord.de

Subject to technical modifications and typographical errors.
For the latest version please visit our web site : www.lenord.de.