

Speed and position sensor MiniCoder GEL 2432

with sin/cos or square-wave output, high-resolution rotational or linear measurement

SENSORLINE

LENORD+BAUER

Technical information

version 08.07

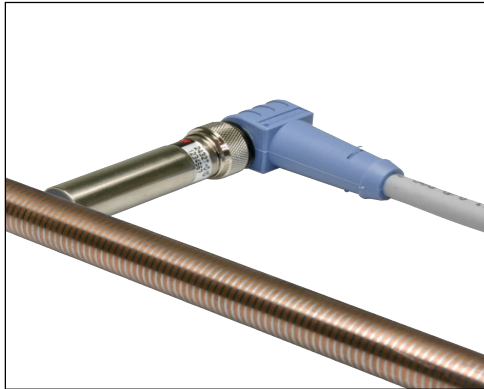

Measuring scales available separately.

Main features

- Sin/cos signal output 1 V_{PP}
- Square-wave signal output 5V TTL / RS422
- High resolution by internal interpolation of square-wave signal output
- Interpolation factor selectable ex works

Properties

- Contactless measurement of rotational motion on target wheels with modules 0.5 and 1.0
- Contactless measurement of linear motion on measuring rods with pitches of 1.0 /1.6 or 2.0 mm
- Useable under the most severe conditions
- Very high protection class IP 67, sensor side chemically resistant
- Fully encapsulated electronics

Fields of Application

- Registering the movement of piston rods on diecasting machines
- Contactless measurement of speeds and positions on machines and motors

Measuring Principle

- Integrated MR sensors for contactless scanning of a target wheel or rod
- Sensor signals are internally enhanced and temperature-compensated
- Frequency range 0 to 200 kHz

Output signals

- Output as square-wave or sinusoidal signals
- Power supply is reverse-polarity protected
- Outputs are short-circuit proof
- Signal forms:
 - Two 90° phase-offset square-wave signals with inverse signals 5V TTL/RS422
 - Sin/cos signals 1 V_{PP} with inverse signals
- Output frequency 0 to 200 kHz
- Amplitude regulation (only for sin/cos signal output)

Technical data

Supply voltage V_s	5 V DC \pm 5%, reverse polarity protected	
Measuring frequency	0 to max. 200 kHz	
Measuring scale	Target wheel / Measuring rod (ferromagnetic)	
Width of target wheel	min. 2.0 mm	
Power consumption unloaded	< 0.2 W	
Operating temperature range	-20 ... +85° C	
Ambient temperature range	-20 ... +85°C	
Storage temperature range	-30 ... +100°C	
Protection class connector side	IP 67 with mounted plug	
Protection class sensor side	IP 67	
EMC	EN 61000-6-1 to 4	
Insulation strength	500 V	
Vibration resistance (IEC 68-2-6)	200 m/s ²	
Shock protection (IEC 68-T2-27)	2000 m/s ²	
Mass	20 g	
Type	2432 T (TTL/RS 422)	2432 K (1 V_{pp})
Output signals	Two 90° phase offset square-wave signals and their inverse signals, short-circuit proof	Sin/Cos signals 1 V_{pp} and their inverse signals, short-circuit proof
Offset (static)	-	< 60 mV
Amplitude tolerance	-	0.8 ... 1.1 V_{pp}
Amplitude alignment V_A/V_B	-	0.95 ... 1.05

Dimensional drawings

Dimensional drawings GEL 2432

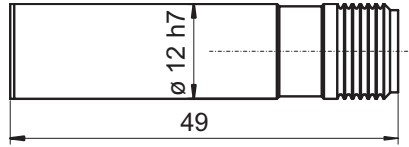

Dimensional drawings GG 600 (Cable with moulded plug, straight outlet)

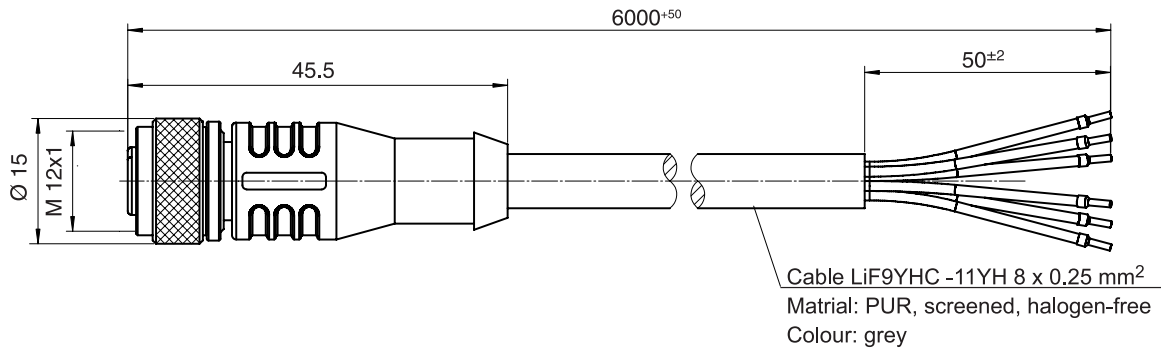

Dimensional drawings GW 600 (Cable with moulded plug, side outlet)

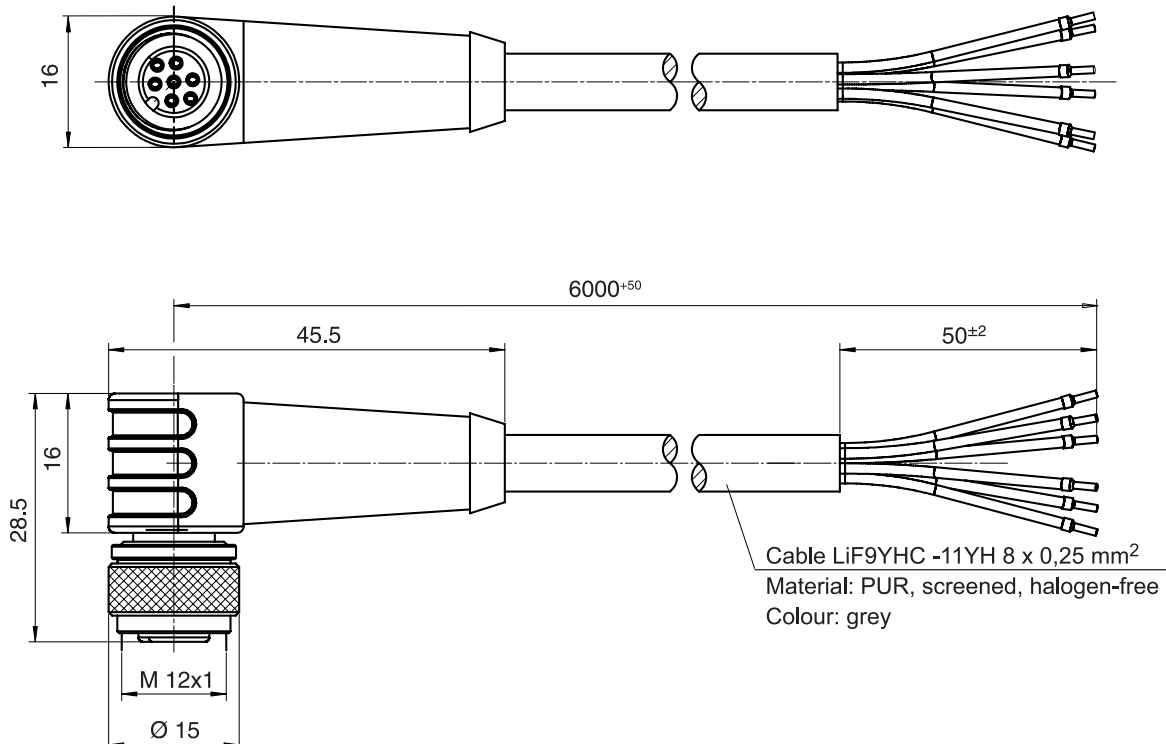

Measuring scales

Measuring rods

Fields of Application

- Length measurements
- Scanning measuring rods with pitch 1, 1.6 or 2 mm

Measuring rods

GEL 2432 series MiniCoders can be used in combination with measuring scales to determine positions of linear movements (e.g. of piston rods). The measuring scale used is a graduated surface structure that can be applied to any desired ferromagnetic machine elements.

This extremely flexible technology makes it possible to use appropriately manufactured piston rods or other machine elements as measuring scales. In the case of piston rods, a special production process is used to fill the applied graduated structure and this is then covered by a wear-resistant hard chrome plating. Other coating materials can also be used as appropriate for the application.

Lenord + Bauer supplies 1.6 mm pitch measuring rods with various diameters.

Measuring rods receive 0.02 mm hard chrome plating. The diameter is accurate to ISO tolerance h6. The surface hardness is ca. 950 ± 50 HV and the surface quality ca. $Ra = 0.2 \mu\text{m}$.

The MiniCoder must be mounted in such a way that the three collinear pins are aligned in the direction of movement of the measuring rod. Observe the position of the plug key in order to establish the counting direction (see the pin layouts for sin/cos or square-wave signal output on page 6).

¹⁾ Distance tolerance applies to sin/cos signals with internal regulation and square-wave signals with interpolation factor 1. Higher interpolation factors have a lower distance tolerance.

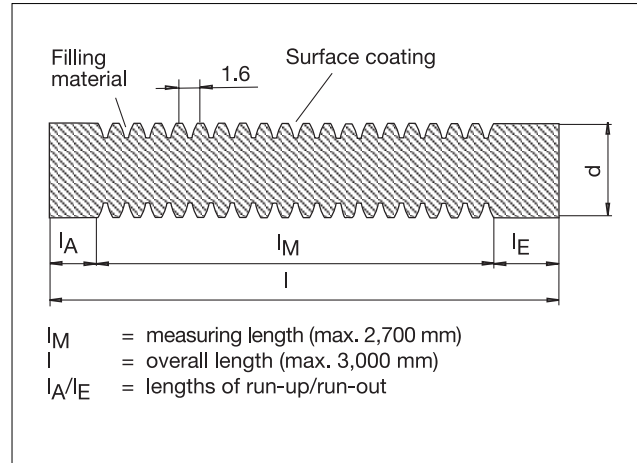

Assembly drawing GEL 2432

Module [mm]	Pitch [mm]	Air gap preset measure	Distance tolerance ¹⁾
-	1.0	0.15 mm	± 0.05 mm
-	1.6	0.25 mm	± 0.05 mm
-	2.0	0.30 mm	± 0.05 mm

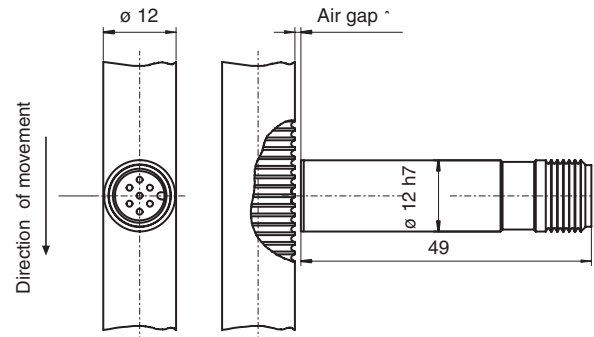

Type codes for measuring rods

		A	Pitch p in mm p = 1.6
			0000 Length in mm (max. 2,700 mm) e. g. 0500
			000 Diameter in mm (h6) 012 / 016 / 020 / 025
MS	-	A	

Measuring scales

Target wheels

Fields of Application

- Length measurements
- Sanning target wheels with module 0.5 or modul 1

Target wheels

The type of MiniCoder that is used to detect rotational motion forms a unit with its target wheel. The size of the target wheel, and hence the diameter of the unit thus depend directly on its module and number of teeth. The following formulae are used:

$$z = (d_a / m) - 2$$

$$d_a = m \cdot (z+2)$$

d_a = external diameter

m = module

z = number of teeth

The MiniCoder must be mounted in such a way that the three collinear pins are aligned in the direction of movement of target wheel. Observe the position of the plug key in order to establish the direction of counting (see the pin layouts for sin/cos or square-wave signal output on page 6).

Customer-specific target wheels

Target wheels can be specially manufactured for individual customers' requirements. Please send us a construction drawing of the desired target wheel (if possible in the form of a DXF file).

¹⁾ Distance tolerance applies to sin/cos signals with internal regulation and square-wave signals with interpolation factor 1. Higher interpolation factors have a lower distance tolerance.



Assembly drawing GEL 2432

Module [mm]	Pitch [mm]	Air gap* preset measure	Distance tolerance ¹⁾
0.5	-	0.25 mm	± 0.05 mm
1.0	-	0.50 mm	± 0.10 mm

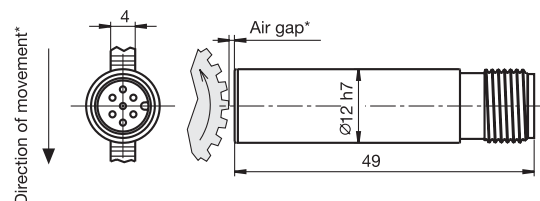

Pin layouts, EMC information

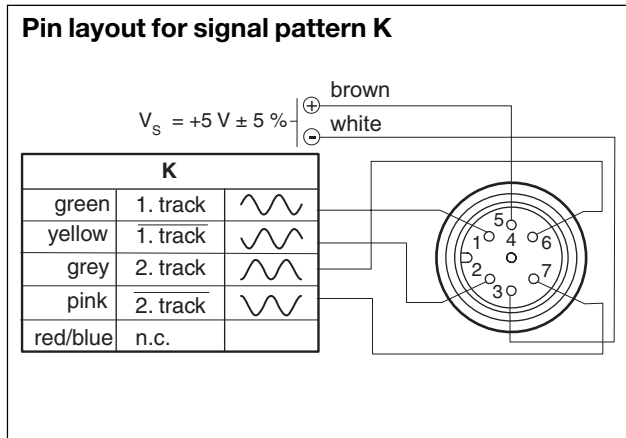

Installation instructions

- Align the MiniCoder **symmetrically** with respect to the measuring scale. Asymmetries lead to measuring errors.
- Avoid mechanical contact between the measuring scale and the 0.1 mm thick protective layer of the sensor system. **Scratching** this protective layer can cause **complete failure** of the MiniCoder.
- Do not damage the surface of the tothing. Do not permit any mechanical components to run on this surface.

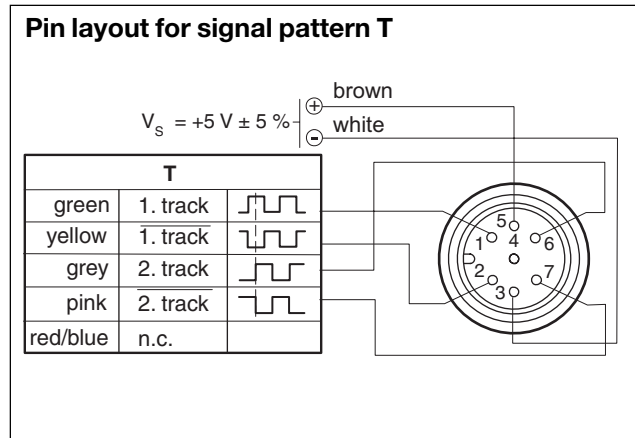

EMC information

In order to maintain the equipment's certificated electromagnetic compatibility (EMC) you should comply with the following instructions:

- The screening at the ends of cables should be in contact **over as large a surface as possible**.
- All unscreened lines should be kept **as short as possible**.
- Earth connections should be made **as short as possible** and should have a **large cross-section** (low induction earthing strap, ribbon cable).
- If there are or may be **potential differences** between the earth connections for machinery and electronic components, then appropriate measures must be adopted to ensure that **no equalising current** can flow via the cable screening (e.g. install a large cross-section equipotential line, or use cables with two-fold separated screening, with each screen in contact at only one side).
- Signal lines and control lines should be routed **separately and away from power cables**.
- The power supply must conform to installation type class 0 or 1 as per item B.3 in the 1995 EN 61000-4-5 standard.

Type code

		Signal pattern	
K		Sin/cos-signal output 1 V _{pp} (with internal amplitude regulation)	
T		Square-wave signal output 5 V TTL / RS 422	
		Interpolation factor (only for signal pattern T)	
	1	Factor 1	
	2	Factor 2	
	4	Factor 4	
	8	Factor 8	
	A	Factor 10	
	B	Factor 12	
	C	Factor 16	
	D	Factor 20	
	R	With internal amplitude regulation (only for signal pattern K)	
		Module / Pitch	
	1	Module m = 1.0 (target wheels)	
	5	Module m = 0.5 (target wheels)	
	A	Pitch p = 1.6 mm (measuring rods)	
	B	Pitch p = 2.0 mm (measuring rods)	
	C	Pitch p = 1.0 mm (measuring rods)	
		0000	Cable with no cable
		C600	Cable with moulded plug, straight (L = 600 cm)
		D600	Cable with moulded plug, angled (L = 600 cm)
2432		-	- - - - -

Interpolation factor

A new electronic module enables the sin/cos signals generated by the MiniCoder GEL 2432 to be interpolated directly.

For example, users can obtain 5000 square-wave signals from a precision 250-tooth target wheel with the selected

interpolation factor D = 20 (higher factors are available on request).

The interpolation is carried out directly at the sensor. The four-flank evaluation facility in the control electronics can deliver an even higher resolution, in the above example 20,000 steps.

Accessories

GEL 212/213 and GEL 214

External interpolation electronics to convert sinusoidal signals to square-wave signals.

If you would like any further information about these products, please ask for our separate technical information sheets, or download them as PDF files from our website:

www.lenord.de.



GG 600 Cable with moulded plug, straight, length 600 cm

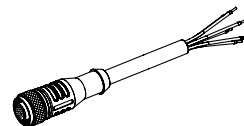

GW 600 Cable with moulded plug, angled, length 600 cm

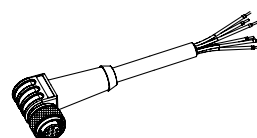

We have agencies in:

Austria
Belgium
Canada
Denmark
Finland
France
Germany
Great Britain
Israel
Italy
Korea
Malaysia
Norway
Portugal
Sweden
Switzerland
Spain
the Czech Republic
the Netherlands
the USA
Turkey



Lenord, Bauer & Co. GmbH
Dohlenstrasse 32
46145 Oberhausen, Germany
Phone: +49 208 9963-0
Fax: +49 208 676292
info@lenord.de
www.lenord.de

Subject to technical modifications and typographical errors.
For the latest version please visit our web site : www.lenord.de.